

O-Ring Roller Conveyor

Contents

[Overview](#)[O-ring roller conveyor sections](#)[Powered straight sections](#)[Powered curved section](#)[Skewed sections](#)[Unpowered sections](#)[Applications](#)[Technical Specifications](#)[Accessories](#)[Assembly Instruction and](#)[Installation Procedure](#)[Maintenance and Support](#)[1- Maintenance](#)[2- Support](#)

Overview

This datasheet covers the different O-ring roller conveyors available at Vention, as well as their various applications for automation in different industries. It also details the technical specifications of each conveyor as well as their required calculations. The ending of the document focuses on the installation of the conveyors and provide a guide to configure it with an simple and efficient code-free conveyor application example.

O-ring roller conveyor sections

Vention's pre-assembled conveyor sections were design in a simple and smart way to ensure an easy initial set up and long lasting performance. From a simple straight segment to a full conveyor application, it has never been so easy to design a conveyor system. All our sections are compatible with each other, as well as our full Vention's ecosystem.

All sections are equipped with provisions to add sensors, cable management cut-outs, and are compatible with many Vention accessories, including modules, leg adjustment, angle adjustment, pneumatic pushers and end stops.

Powered straight sections

Our straight sections are available in 2 lengths : 630 mm and 1575 mm. It is also possible to choose between having 2 or 3 zones for the 1575mm segments, depending on the required performance.

Part Number	Description	Length	Number of rollers	Number of zones
MO-CV-030-0001	O-Ring roller conveyor 1575 mm powered straight section with 2 zones	1575	20	2
MO-CV-030-0002	O-Ring roller conveyor 1575 mm powered straight section with 3 zones	1575	20	3
MO-CV-030-0016	O-Ring roller conveyor 630 mm powered straight section with 1 zone	630	8	1

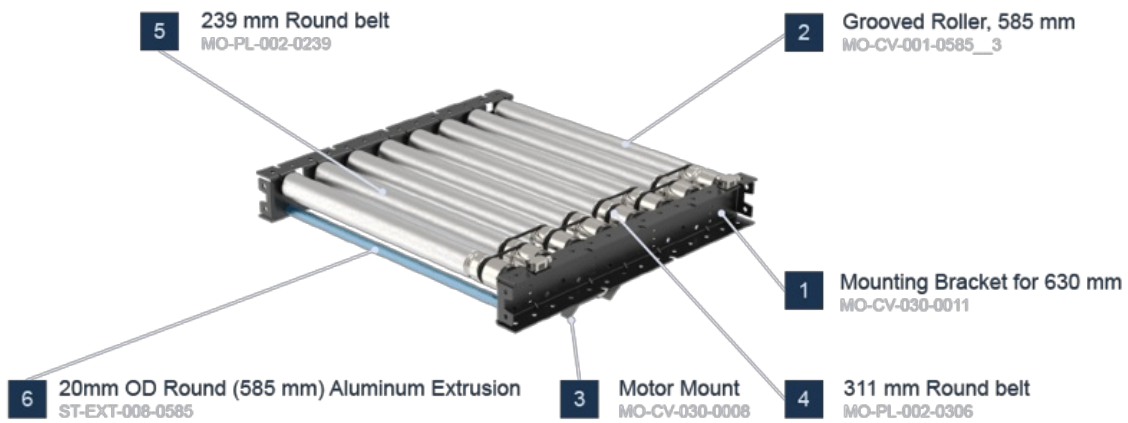
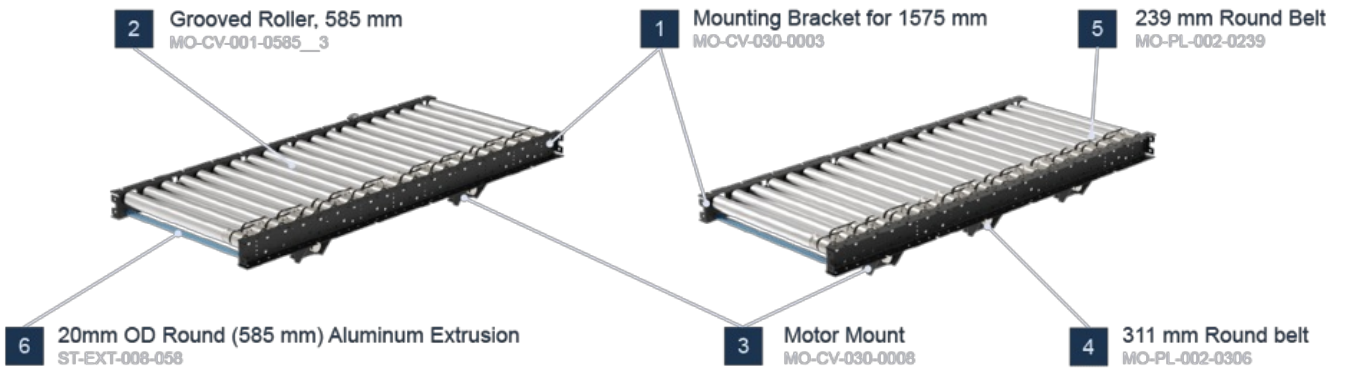

Powered curved section

Tapered rollers are used for the curved section (MO-CV-030-0012) of our o-ring roller conveyor family. This one zone, 45° section offers a quick and easy conveyor turn solution. Simply have two of these together to complete a 90° turn with 2 zones.

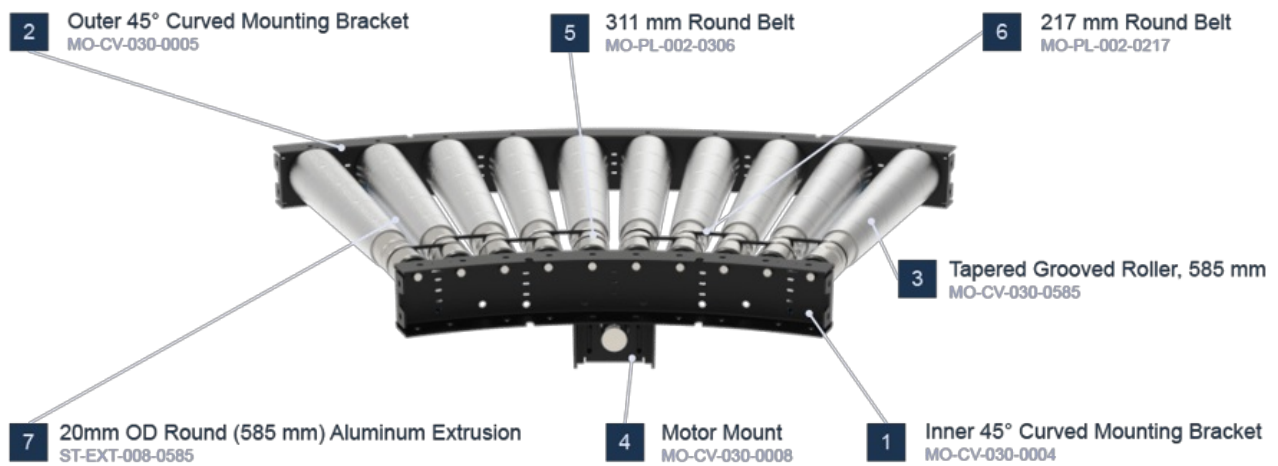

Skewed sections

Vention's new roller conveyor family also offer a set of skewed conveyors, to fulfill any additional box movement needed for palletizing or any other application they might be required. The four sections below allow left and right directions with 2 or 3 zones. Note that the skewed angle is 7.6° . A bracket and small rollers are available as individual parts to offer a smooth transition between different types of sections.

Part Number	Description	Length	Number of rollers	Number of zones
MO-CV-030-0013	O-Ring Roller Conveyor 1575 mm Powered Skewed Section with 2 Zones, Right to Left Direction	1575	19	2
MO-CV-030-0014	O-Ring Roller Conveyor 1575 mm Powered Skewed Section with 3 Zones, Right to Left Direction	1575	19	3
MO-CV-030-0018	O-Ring Roller Conveyor 1575 mm Powered Skewed Section with 2 Zones, Left to Right Direction	1575	19	2
MO-CV-030-0019	O-Ring Roller Conveyor 1575 mm Powered Skewed Section with 3 Zones, Left to Right Direction	1575	19	3

For Covering the end gaps in right to left skewed conveyors (MO-CV-030-0013 and MO-CV-030-0014), a Cover Bracket (MO-CV-030-0020) and a 180 mm grooved roller (MO-CV-001-0180) can be installed at both ends of the conveyor.

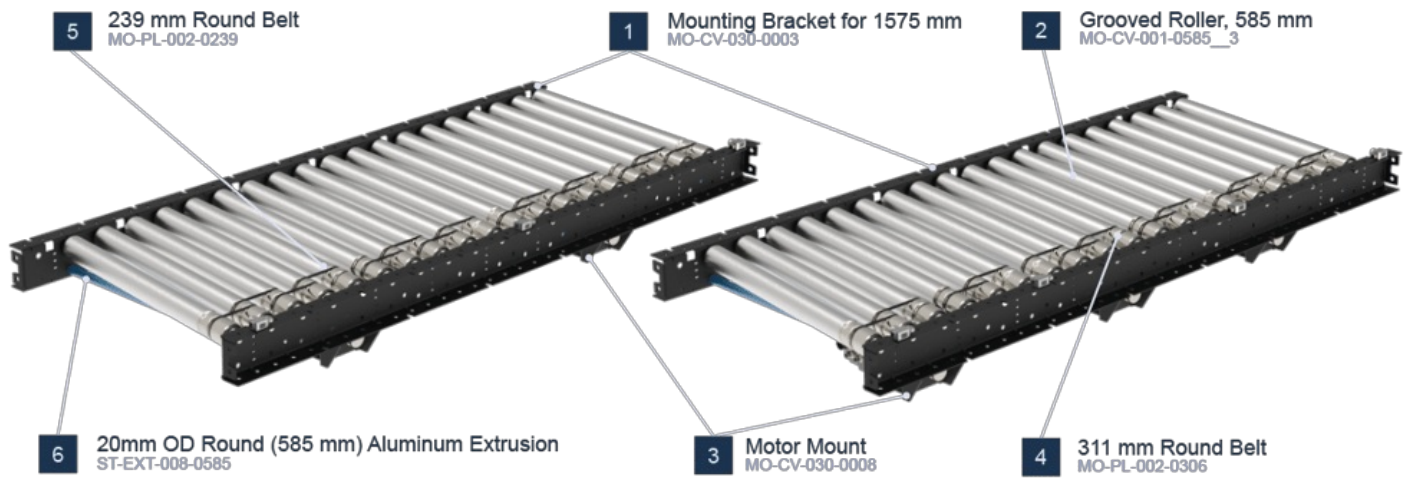

Right to left powered skewed section

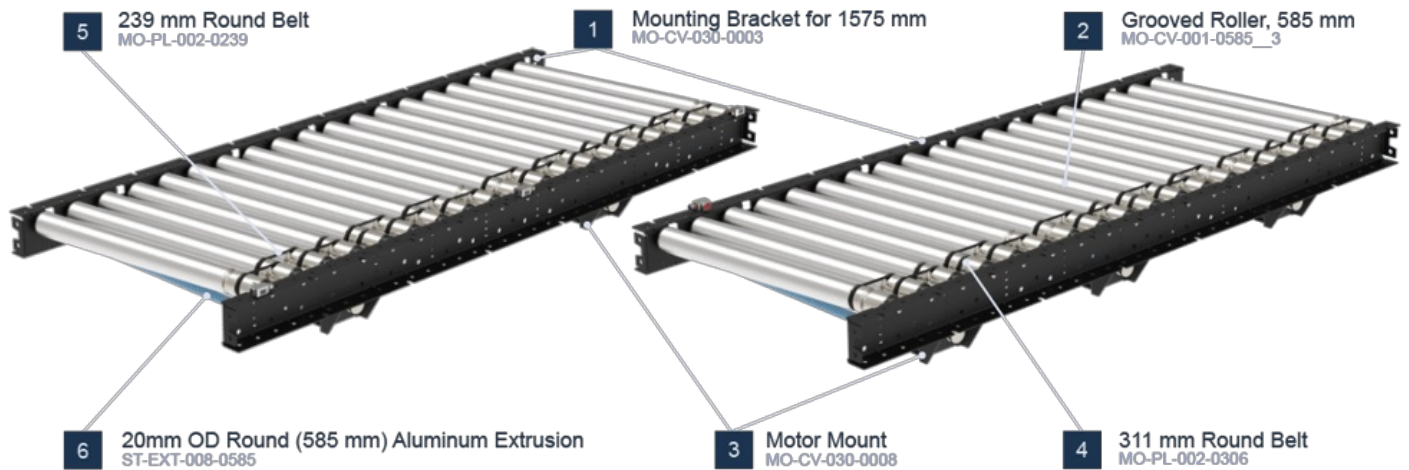

Left to right powered skewed section

Unpowered sections

Finally, if no power is necessary for the application, it is possible to use a straight 1575 and 630 straight sections, such as gravity conveyors.



1575 mm gravity section



630mm gravity section

Applications

Conveyors are used to move loads from one point to another. Our O-ring conveyor family offers possibilities to create applications that vary from simple gravity conveyors to complex systems with indexing and zero pressure accumulation. Visit our design library for sample designs of different applications. Here are a few examples:

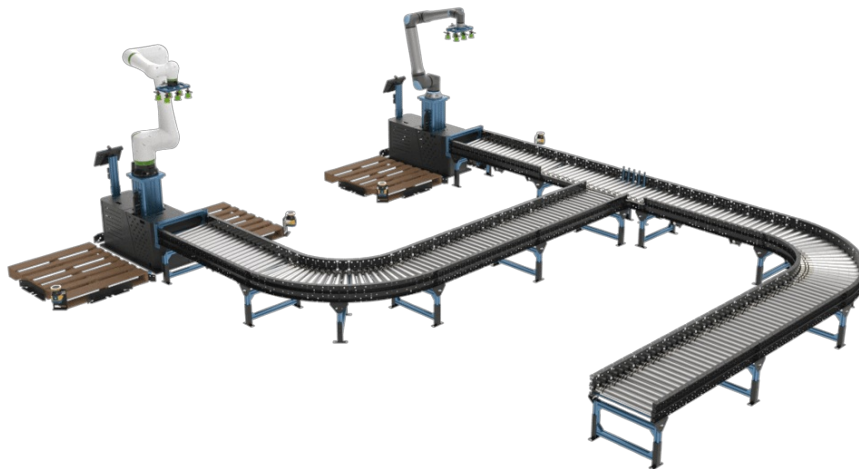

Dual palletizer with sorting/pusher

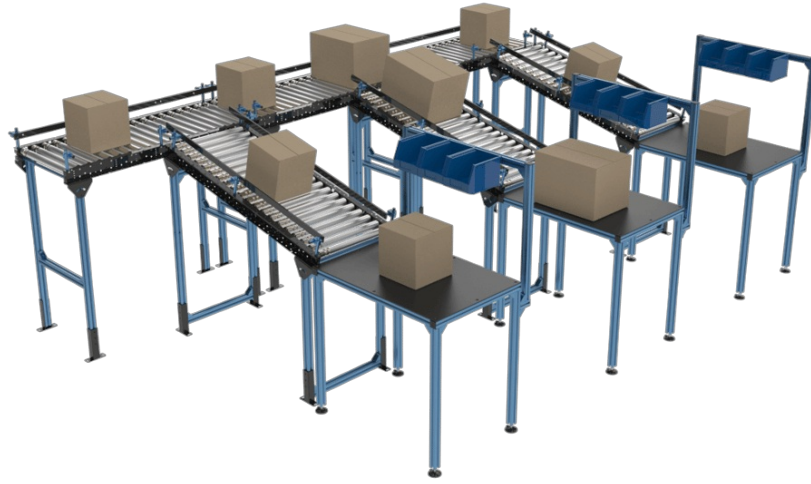

Sorting station



Single palletizer with skewed section

[Browse open source designs](#)

To build a conveyor using our Machine Logic code-free conveyor application example, consult the following guide and download the python file to generate the application.

[Conveyor Application Example Guide](#)

Technical Specifications

Section types

powered straight, powered curved, powered skewed, unpowered straight

**** Application Type****

zero pressure accumulation

Lengths	630 mm or 1575 mm
Pitch	78.75 mm
Roller Width	585 mm
Between Frame width (BF)	585 mm
Max Payload per zone	40 kg
Max speed	305 mm/s (60 ft/min)
Min speed	150 mm/s (30 ft/min)
Displacement ratio	92.82 mm per revolution
Min box size	160 mm in length
Roller material	zinc plated steel
Max angle of powered inclined conveyor	10° (when load going up)
Max load for inclined conveyor with 10° angle	15 kg (when load is going up)

Accessories

1) Leg adjustments

The two following leg and conveyor adjustments are available and fully compatible with this o-ring conveyor family.

1. Height Adjustment bracket: This bracket allows a quick and simple way to adjust the conveyor to any existing equipment. Max translation is 150 mm
2. Angle Adjustment bracket: The angle adjustment bracket is a key part for all gravity conveyors, while also allowing to adjust the conveyor to existing equipment.

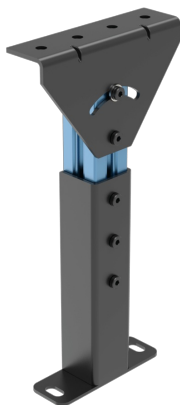

Height and angle adjustments

2) Modules, sensors and cable management

a) Sensor Mounts

Each C-channel of Vention's O-ring conveyor family is equipped with specific placement for sensors, making it easy to install without additional hardware. It is also possible to use any existing hole, with the addition of the sensor bracket ([CE-HW-001-0003](#)).

b) I/O and E-Stop modules

There are several options for installing the I/O and E-Stop modules, either using the vertical extrusions or using a simple extrusion structure attached beneath the conveyor c-channel, as shown below.

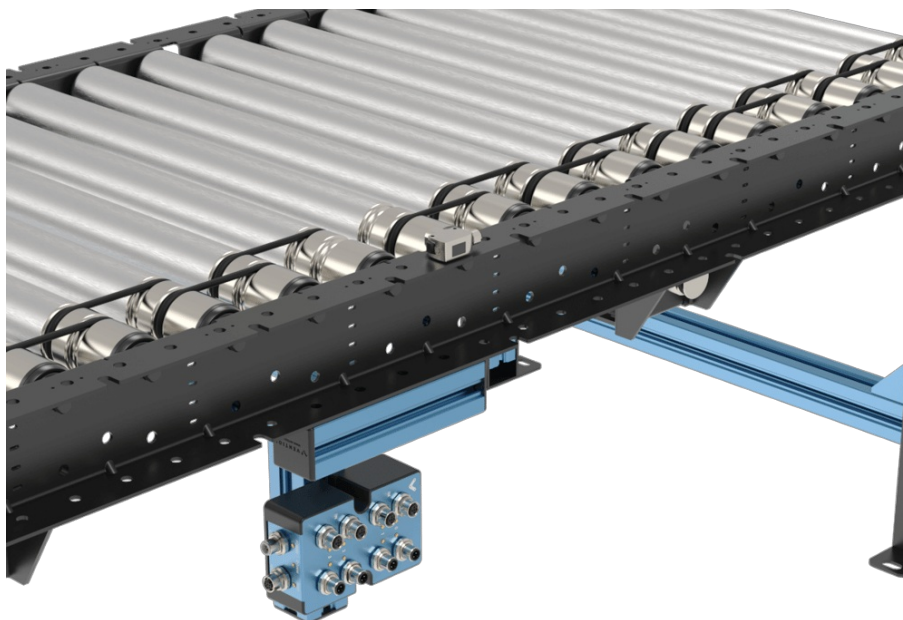

Module and sensor installation

c) Cable Management

The C-Channel brackets is equipped with cutouts to allow easy cable management coming from sensors, modules and motor cables to prevent chaffing and offer a clean integration set up. It is also possible to use zip-ties to secure cables using the designated holes along the C-Channel.

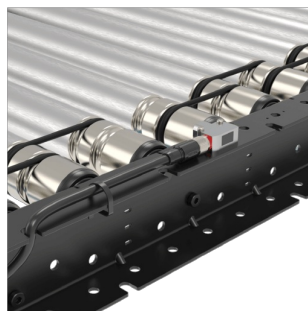
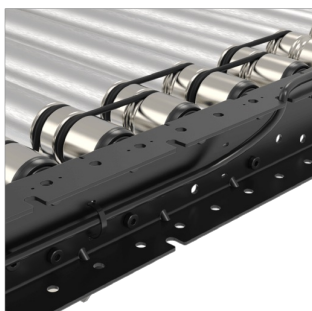

3) Side guard

a) Mounting bracket as side guard

The C-channels mounting the rollers are versatile and can also be used as a guiding system on all sections. The c-channel can simply be superposed over the actual conveyor section. Associated fasteners are included in each C-Channel to ensure a safe installation.



Straight mounting bracket as side guide



Curve mounting bracket as side guard

Another great perk of having a channel as a side guide is being able to install sensors underneath the top bracket in its designated cut-outs. This will allow maximum protection of the sensor.



Sensor behind guard



Sensor behind guard (other side)

b) Flexible guides (straight sections only)

Flexible guards ([ST-PN-020-2295](#)) can be cut to the required length to be able to direct, index or funnel boxes along a conveyor during material handling operations. Using our well known round extrusion, flexible guide provide an adjustable solution for flexible guide. For more details, refer the to the [Flexible Conveyor Guide section](#) of the Material Handling Datasheet

4) Pneumatic pushers

In palletizing applications, to have the box on a certain location on the conveyor at the end of the line and close to the robot to pick up, a pneumatic pusher is used to push the box to the side of the conveyor. It is possible to install the pneumatic pusher in a simple way on Vention's new o-ring conveyors. Follow

these steps for a quick and easy design:

1. Install short 45x45 extrusion on top of the conveyor c-channel using associated fasteners from the conveyor
 - M8 serrated nuts (HW-FN-031-0002)
 - M8x18 mm screws ([HW-FN-003-0018](#)) and
 - M8 split washers ([HW-WS-001-1003](#))
2. Design and install an additional leg made of extrusion, with the same height as the conveyor. Below image shows a T-shaped leg to hold the pusher.
3. Install the pusher on top of the conveyor and the additional leg.

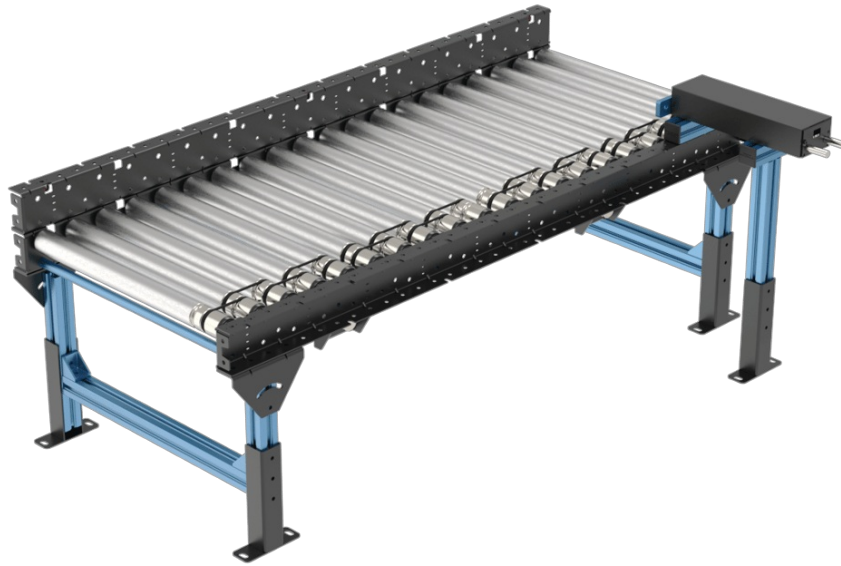

Pneumatic pusher installation

5) End Stop

An end stop can be easily made out of two GP gussets ([GT-GP-003-0005](#) or [ST-GP-003-0001](#)) and a 45x45 mm extrusion between them. It can be installed on top of the conveyor c-channels using the following fasteners:

1. M8x18 mm screws ([HW-FN-003-0018](#)) provided with the gussets
2. M8 Serrated Flange Locknut (HW-FN-031-0002) provided with the conveyor.



End Stop example

Assembly Instruction and Installation Procedure

In order to complete a full conveyor section, including legs, follow the instructions below. In order to ease the procedure, a powered 1575mm section of 2 zone will be used as an example.

1) Assemble the legs

1. Install the Height Adjustment Bracket (MO-CV-030-0007) on all four 45x45mm extrusions (ST-EXT-001-XXXX) using three M8 T-nuts (HW-FN-002-0001) and three M8x16mm ([HW-FN-003-0016](#)). Torque them to 15 N.m.
2. It is suggested to maintain a gap between the bottom of the extrusion and bottom of the Height adjustment Bracket of approximately 22.5mm. This is done to ensure that the brackets can be adjusted in either direction in the case of a very uneven floor.



3. Install the angle adjustment bracket (MO-CV-030-0006) on the upper side of the 45x45mm extrusion above using two M8 T-nuts with M5 set screw ([HW-FN-002-0008](#)), two M8x16mm ([HW-FN-003-0016](#)) and one M8 washer (HW-WS-001-0001).
Note: Do not fully tighten the M8 screw on the curved slot at this stage.
4. Maintain a gap of approx. 20mm between the top of the extrusion and inside face of the Angle Adjustment Bracket. This will allow the rotation of the bracket to its desired location. Tighten the M8 screws to 15 N.m.

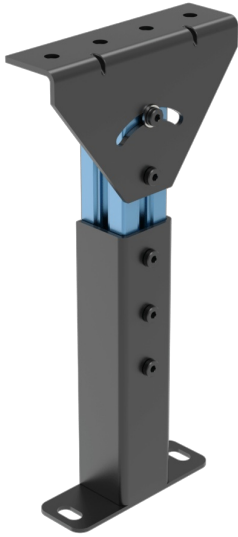

5. Repeat step 1 to 3 for all legs of the conveyors. (4 legs per segment)
6. Install the assembled legs at each extremities of the conveyor c-channel mounting brackets using four M8x16mm screws (HW-FN-003-0016). Torque them to 15 N.m.

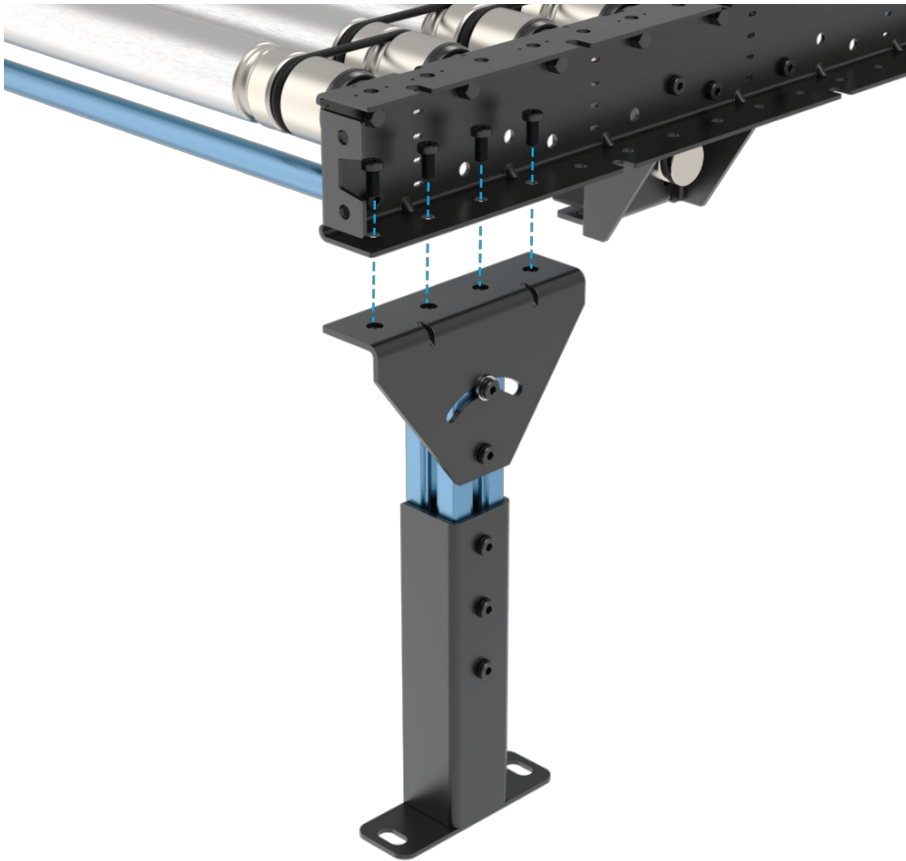

7. Use a level on the c-channel mounting bracket and on a roller. Adjust the height of each individual leg on the height adjustment bracket and re-tighten the screws once the level is acceptable. It is normal to have the height of each legs uneven due to the floor having imperfections.



8. Install one 45x45mm extrusion ([ST-EXT-001-0585](#)) with the length of 585mm between each leg using two 45x45 gussets ([ST-HP-003-0001](#) or [ST-GP-003-0001](#)).

2) Motor adaptor installation

1. Place the motor adaptor at the highest position and use four M6x18mm (HW-FN-005-1018) and four M6 washers (HW-WS-005-0001) to attach it to the motor mount of the conveyor.

Note 1: Do not fully tighten them at this stage.

Note 2: When installing the motor adaptor on the motor mount of the conveyor, the two M6 threaded holes on the side of the motor adaptor **must** be facing down (towards the ground) for tensioning in the next step.

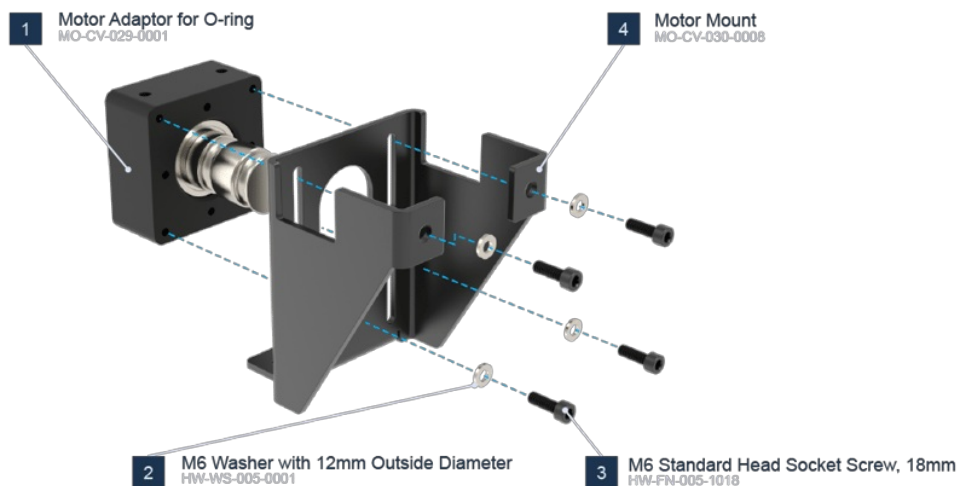

2. Use two M6x70mm (HW-FN-005-1070) and two M6 washers (HW-WS-005-0001) at the location shown below on the Motor Mount (MO-CV-030-0008) and connect the screws to the threaded holes on the bottom of Motor Adaptor (MO-CV-029-0001).

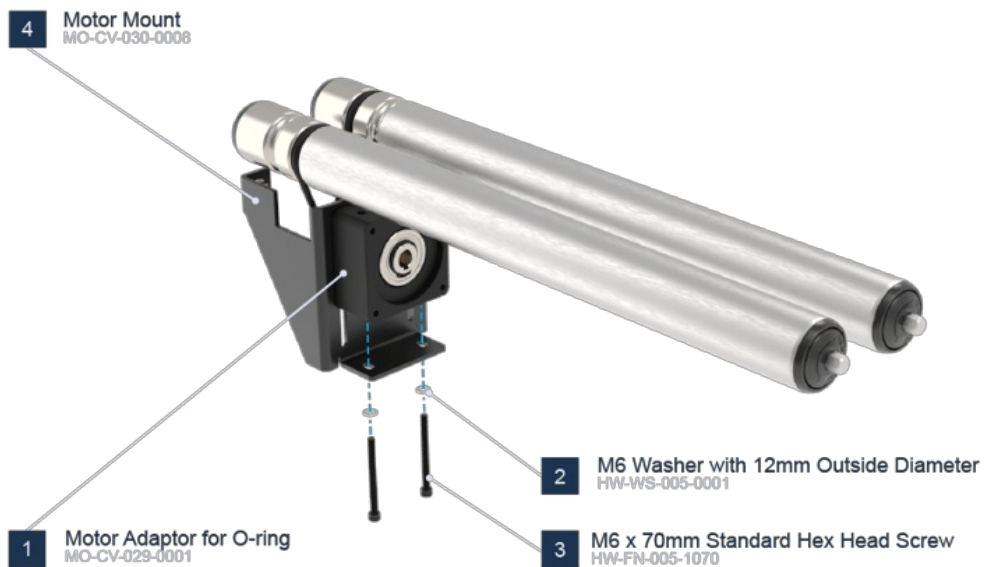

3. Lower the 2 hanging o-rings (MO-PL-002-0306) onto the grooved shaft of the motor adaptor.
4. While having the four screws on the Motor Mount (MO-CV-030-0008) slots still loose, use the two M6x70mm (HW-FN-005-1070) screws to bring down the motor adaptor . The motor adaptor will slide down and create tension in the o-rings on the shaft.
5. When the motor mount is in its final position on the vertical slots, just slightly tighten the two M6x70 mm (HW-FN-005-1070) screws (do not fully tighten). There will be a gap between the bottom of the motor adaptor and the motor mount. Now tighten the four M6x18mm screws (HW-FN-005-1018) to 9 -11 N.m.

3) Floor anchoring

1. The conveyor must be anchored to the floor. Use four 3/8 x 3" Concrete Screw Anchor (HW-FN-051-2076) for each Height Adjustment Bracket (MO-CV-030-0007).

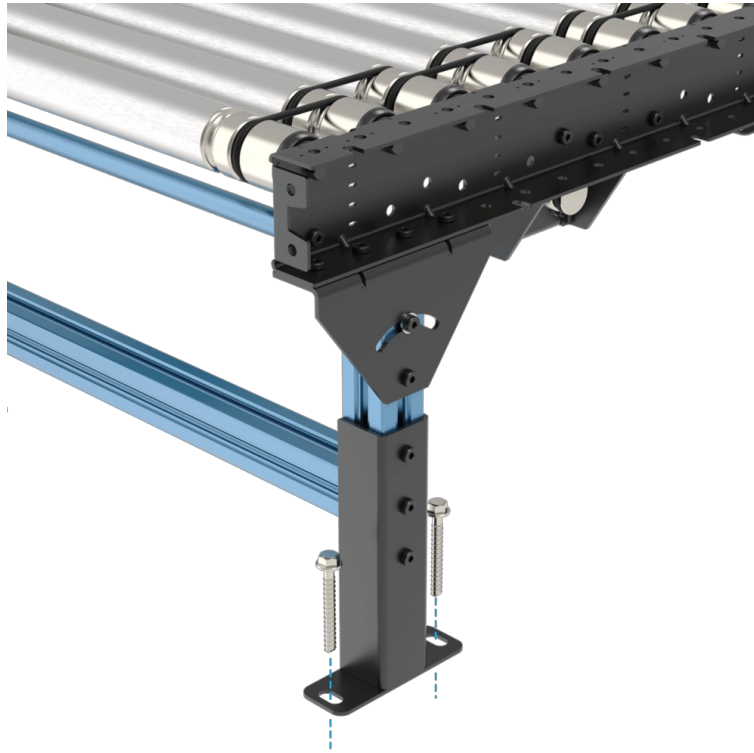

Floor anchoring

4) Sensor installation

1. If required by the application, install diffuse sensors per design using two M3x18mm (HW-FN-009-0018) which come with the sensor. torque the M3 screws to 1.2-1.4 N.m.

Note: The location of the sensors is dictated by the application type. In case of zero accumulation applications, one sensor is needed at the beginning of the conveyor and one sensor at the end of each zone. For installation refer to the MachineBuilder design of the application to ensure that the locations of the sensors are correct.

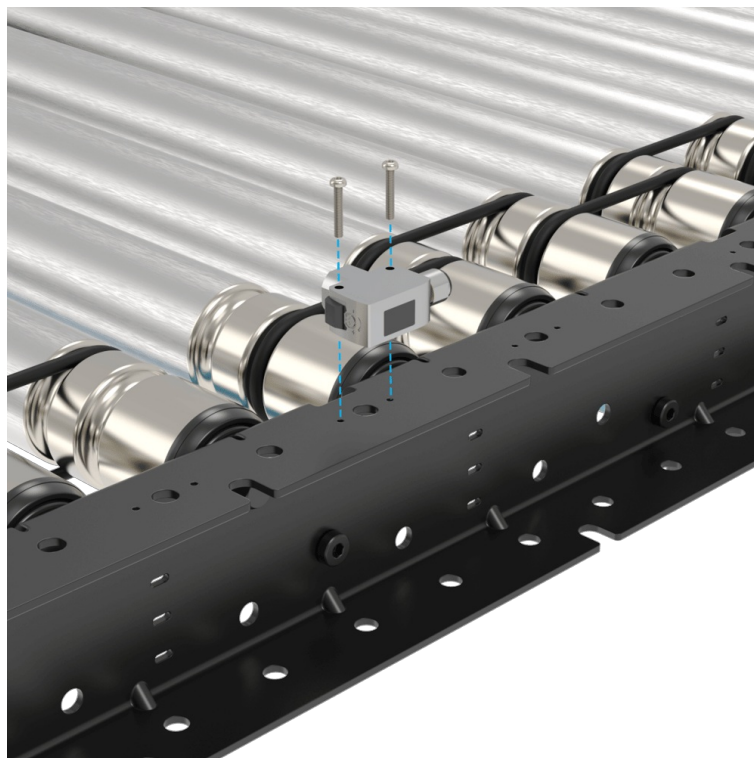

sensor installation

5) Skewed section

For Covering the end gaps skewed conveyors (MO-CV-030-0013 and MO-CV-030-0014), a Cover Bracket (MO-CV-030-0020 left), (MO-CV-030-0021 right) and a 180 mm grooved roller (MO-CV-001-0180) can be installed at both ends of the conveyor.

1. Place the cover bracket between the c-channels of the conveyor, parallel to the rollers, and connect it to the conveyor using the associated fasteners
 - 2x M8 serrated nuts (HW-FN-031-0002),
 - 2x M8 split washers (HW-WS-001-1003)
 - 2x M8x18 mm screws (HW-FN-003-0018)Torque the M8 screws to 15-18 N.m.

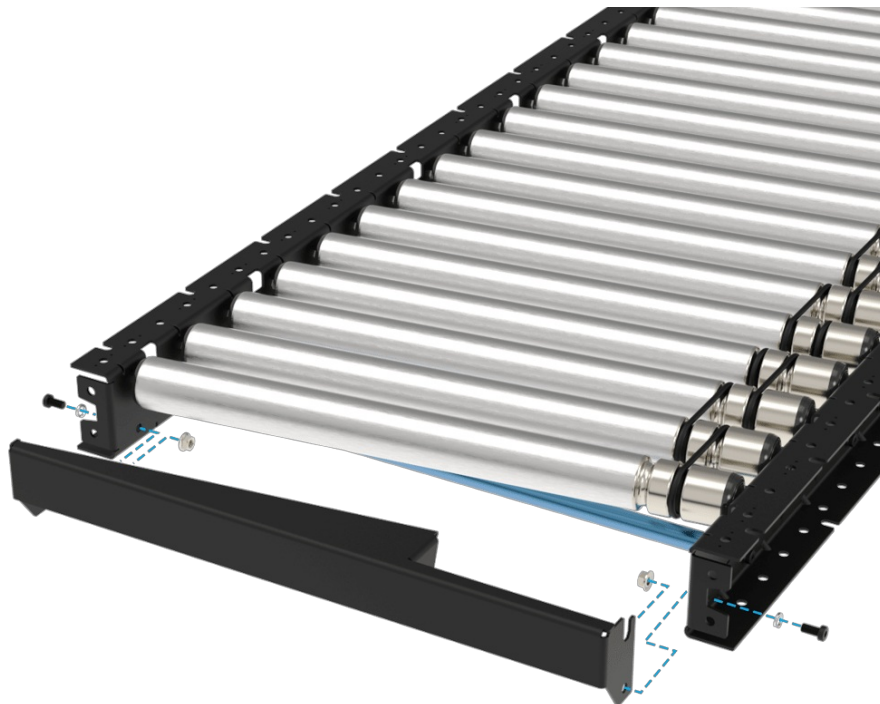

2. Place the small roller (MO-CV-001-0180) inside the cover into the shown location by inserting in the hex shaft of the small roller into the hex hole of the conveyor and then pressing the other side of the spring loaded shaft in to the hex hole of the cover bracket.



Short roller installation

Note: The installation process is similar to all skewed configuration.

To join two skewed sections, simply add another roller and o-ring set to the BOM. This way it will be possible to fill the gap with only an additional roller.



Join two skewed section

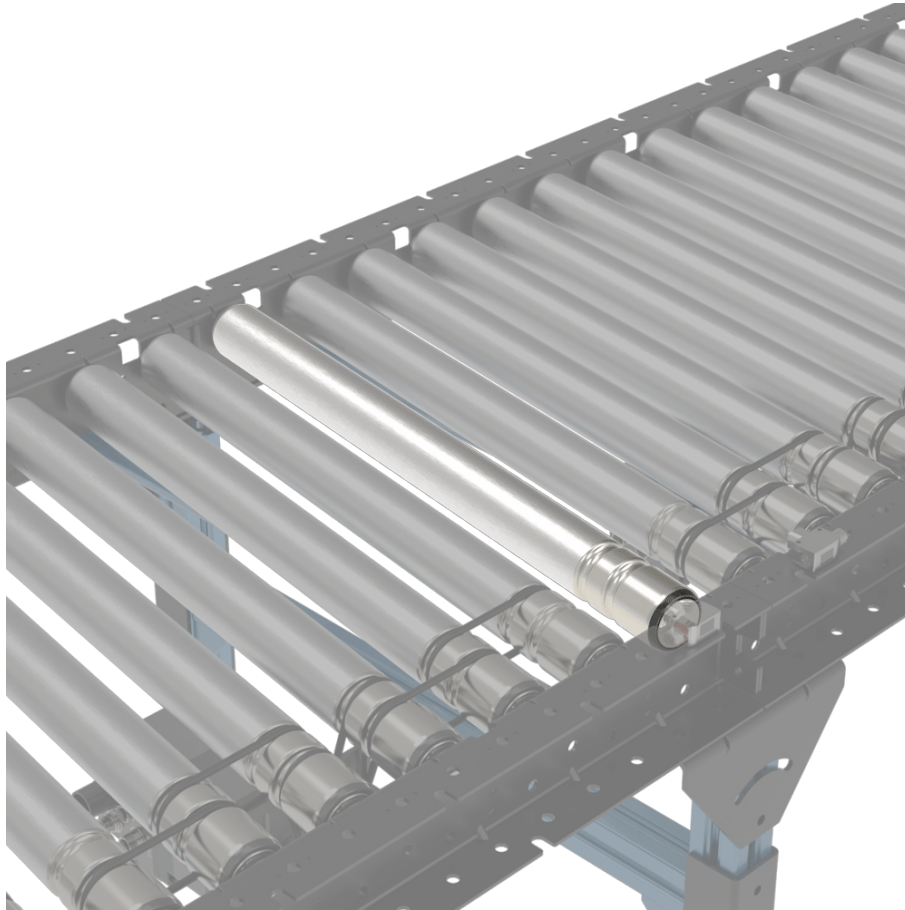

Additional roller between two skewed sections

6) Butt-Joining of conveyors

For butt-joining 2 conveyors, only one Angle Adjustment Bracket is required at the joint. Also, the conveyors can be connected to each other using 2 holes on the end of c-channels. Use the extra associated fasteners coming with the conveyor including M8 serrated nuts (HW-FN-031-0002), M8x18 mm screws (HW-FN-003-0018) and M8 split washers (HW-WS-001-1003) to connect the sections together like the picture below. Torque the M8 screws to 15-18 N.m.



Butt joining of tow conveyors

Maintenance and Support

1- Maintenance

In case of failed o-rings, first cut the failed o-ring. Then push in the spring-loaded hex shaft of the non-oring side of the 2 rollers. See the picture below.

Install the new o-ring on one of the rollers and then use Vention's O-ring installer tool (HW-TL-004-0003) to stretch the new o-ring to allow enough clearance for the next roller to pass through. See the picture below.

Conveyor Type	Part Number
Straight section	MO-PL-002-0239
Curve section	MO-PL-002-0217
Roller to Motor Adaptor (all powered sections)	MO-PL-002-0306

2- Support

Should a different configuration than the ones mentioned above would be required, reach out to our application specialist team.